

Included:

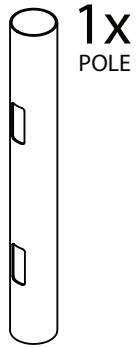

1x
POLE

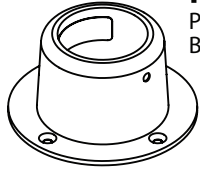

1x
POLE MOUNTING
BASE

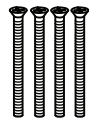

4x
#10 X 2.50 LONG
PHILLIPS SCREW



1x
.25-20 X .38
LONG SET SCREW



4x
#10 FLAT WASHER



4x
10-32 NYLOCK NUT

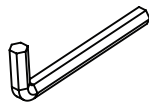

4x
1/8" HEX KEY
3/16" HEX KEY
5/32" HEX KEY
5/64" HEX KEY



1x
STOP PLATE



4x
#10 X 1.00 LONG
PHILLIPS SCREW

Tools Needed:

- \varnothing 2.00 in. HOLE CUTTER

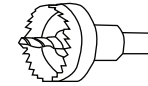

- #2 PHILLIPS SCREW OR DRILL DRIVER



- 1/8" HEX KEY



1a.
Mounting Option A

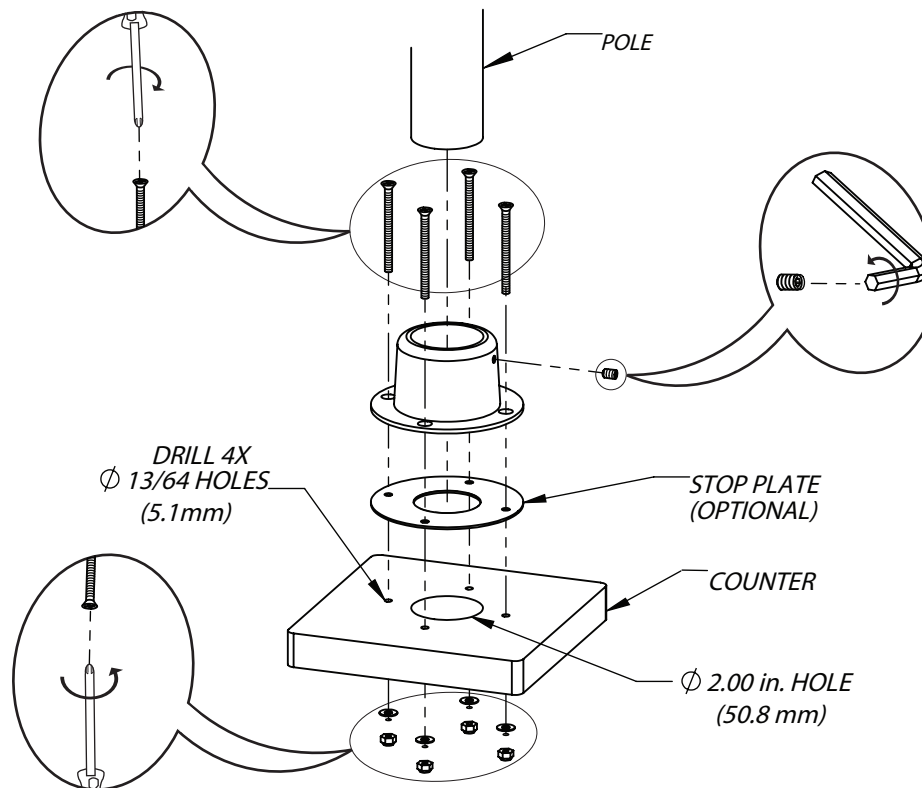

2a.

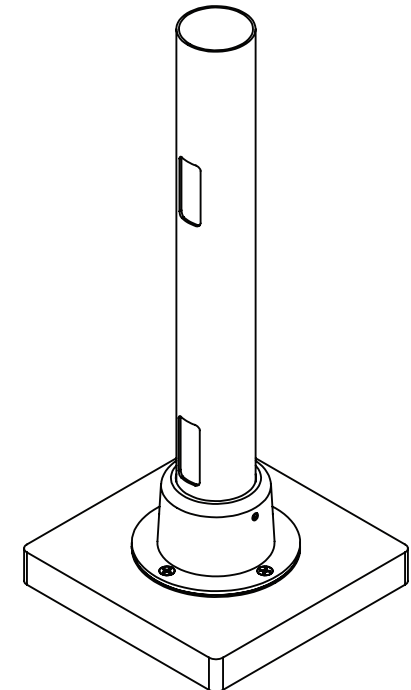

1b.

Mounting Option B

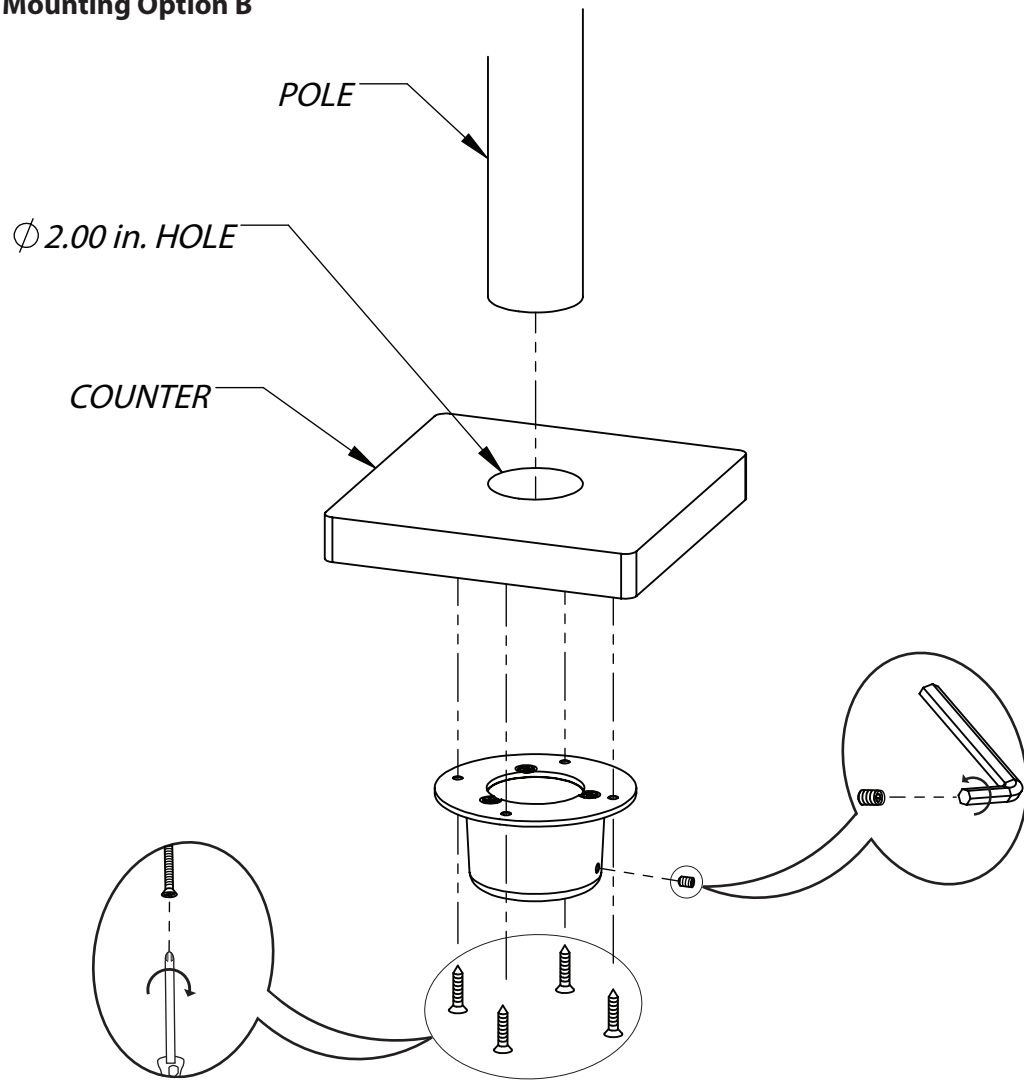

2b.

